

The Emissions Collection and Monitoring Plan Project

Monitoring Plan XML Schema Version 1.1

Submitted to:

ECMPS Stakeholders

Submitted by:

United States Environmental Protection Agency
Office of Air and Radiation
Clean Air Markets Division
1310 L Street, NW
Washington, DC 20005

March 9, 2011

List of Figures

	<u>Page</u>
Figure 1 MonitoringPlan.....	2
Figure 2 MonitoringPlan XML Elements.....	2
Figure 3 Complex Elements of the Monitoring Plan Root.....	2
Figure 4 AnalyzerRangeData.....	3
Figure 5 AnalyzerRangeData XML Elements.....	4
Figure 6 ComponentData.....	4
Figure 7 ComponentData XML Elements.....	5
Figure 8 MonitoringDefaultData.....	6
Figure 9 MonitoringDefaultData XML Elements.....	6
Figure 10 MonitoringFormulaData.....	7
Figure 11 MonitoringFormulaData XML Elements.....	8
Figure 12 MonitoringLoadData.....	9
Figure 13 MonitoringLoadData XML Elements.....	9
Figure 14 MonitoringLocationData.....	10
Figure 15 MonitoringLocationData XML Elements.....	11
Figure 16 MonitoringLocationAttribData.....	11
Figure 17 MonitoringLocationAttribData XML Elements.....	12
Figure 18 MonitoringMethodData.....	13
Figure 19 MonitoringMethodData XML Elements.....	13
Figure 20 MonitoringPlanCommentData.....	14
Figure 21 MonitoringPlanCommentData XML Elements.....	14
Figure 22 MonitoringQualificationData.....	14
Figure 23 MonitoringQualificationData XML Elements.....	15
Figure 24 MonitoringQualLMEDData.....	15
Figure 25 MonitoringQualLMEDData XML Elements.....	15
Figure 26 MonitoringQualPercentData.....	16
Figure 27 MonitoringQualPercentData XML Elements.....	16
Figure 28 MonitoringSpanData.....	18
Figure 29 MonitoringSpanData XML Elements.....	18
Figure 30 MonitoringSystemData.....	20
Figure 31 MonitoringSystemData XML Elements.....	20
Figure 32 MonitoringSystemComponentData.....	21
Figure 33 MonitoringSystemComponentData XML Elements.....	21
Figure 34 MonitoringSystemFuelFlowData.....	22
Figure 35 MonitoringSystemFuelFlowData XML Elements.....	22
Figure 36 RectangularDuctWAFData.....	23
Figure 37 RectangularDuctWAFData XML Elements.....	24
Figure 38 StackPipeData.....	25
Figure 39 StackPipeData XML Elements.....	26
Figure 40 UnitData.....	27
Figure 41 UnitData XML Elements.....	28
Figure 42 UnitCapacityData.....	28
Figure 43 UnitCapacityData XML Elements.....	28

List of Figures (cont.)

	<u>Page</u>
Figure 44 UnitControlData	29
Figure 45 UnitControlData XML Elements	29
Figure 46 UnitFuelData	30
Figure 47 UnitFuelData XML Elements.....	30
Figure 48 UnitStackConfigurationData	31
Figure 49 UnitStackConfigurationData XML Elements	31
Figure 50 Simple Types Used for Validation	32

Monitoring Plan XML Schema Version 1.1

1.0 Introduction

This document is the first in a series that outlines the Extensible Mark-up Language (XML) schema and how data files must be formatted for the Emissions Collection and Monitoring Plan System (ECMPS). A schema has been developed for each data type, i.e., monitoring plan, quality assurance and certification test data, emissions data. The schema will be used for all monitoring plan data that are imported into the ECMPS Client Tool and exported from the Client Tool. The move to XML will allow users to submit only the necessary data for a given submission of data. It will also allow for more robust data validation through the XML schema.

The schema is included in a separate file. The schema may be viewed in any application that is able to display text files or an application specifically designed for viewing XML schema.

2.0 Monitoring Plan XML Schema Tables

The following tables provide information about the data elements of the Monitoring Plan XML schema. The information includes a description of the data element, the type of the element, and, where appropriate, a reference to the relevant EDR record type and column. If an exact correspondence between a single EDR record type and column and a data element could not be made, the column in the table will include the "N/A" designation. In other cases because the data have been restructured, it was not possible to make an exact match between a record type and column and a data element. In these cases, the record type and column are marked as "N/A."

Figures 1 and 2 provide information on the root element of the Monitoring Plan XML schema. Figure 3 lists all of the complex data elements and information that indicates the parent-child relationship between the major data elements. Figures 4 through 49 include information on the complex data elements in the XML schema.

Detailed information about the data types is included in Figure 50. The term "optional" is often used in the names of the various data types. The term "optional" in the name of these data validation data types only refers to the fact that the schema validation will accept a data element tag that does not include a value (an empty tag). Depending on the data being reported, these data elements might require data to be reported.

**Figure 1
MonitoringPlan**

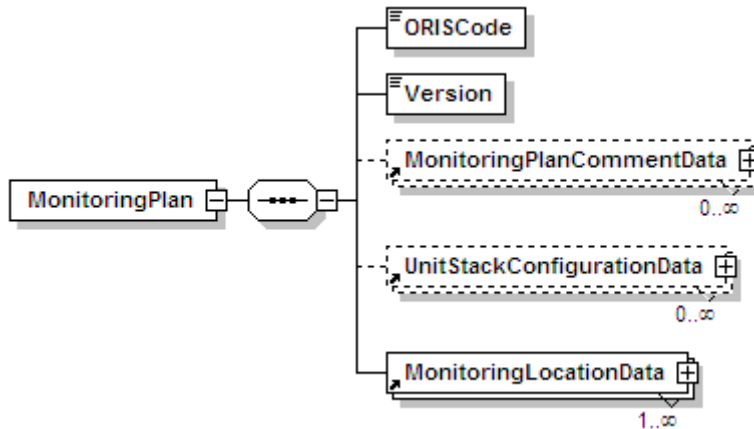

**Figure 2
MonitoringPlan XML Elements**

XML Tag	Type	Definition	EDR Reference (RT:Col)
ORISCode	ORISCodeType	EIA -- assigned identifier or Facility identifier assigned by CAMD (if EIA number is not applicable).	N/A
Version	VersionType	Identifies the XML schema version.	N/A

**Figure 3
Complex Elements of the MonitoringPlan Root**

Complex Element	Parent Element	Minimum Occurrences	Maximum Occurrences
AnalyzerRangeData	ComponentData	0	unbounded
ComponentData	StackPipeData or UnitData	0	unbounded
MonitoringDefaultData	StackPipeData or UnitData	0	unbounded
MonitoringFormulaData	StackPipeData or UnitData	0	unbounded
MonitoringLoadData	StackPipeData or UnitData	0	unbounded
MonitoringLocationAttribData	StackPipeData or UnitData	0	unbounded

(cont.)

Figure 3
Complex Elements of the MonitoringPlan Root (cont.)

Complex Element	Parent Element	Minimum Occurrences	Maximum Occurrences
MonitoringLocationData	MonitoringPlan	1	unbounded
MonitoringMethodData	StackPipeData or UnitData	0	unbounded
MonitoringPlan		1	1
MonitoringPlanCommentData	MonitoringPlan	0	unbounded
MonitoringQualificationData	StackPipeData or UnitData	0	unbounded
MonitoringQualLMEDData	MonitoringQualificationData	0	unbounded
MonitoringQualPercentData	MonitoringQualificationData	0	unbounded
MonitoringSpanData	StackPipeData or UnitData	0	unbounded
MonitoringSystemComponentData	MonitoringSystemData	0	unbounded
MonitoringSystemData	StackPipeData or UnitData	0	unbounded
MonitoringSystemFuelFlowData	MonitoringSystemData	0	unbounded
RectangularDuctWAFData	StackPipeData or UnitData	0	unbounded
StackPipeData	MonitoringLocationData	0	unbounded
UnitCapacityData	UnitData	0	unbounded
UnitControlData	UnitData	0	unbounded
UnitData	MonitoringLocationData	0	unbounded
UnitFuelData	UnitData	0	unbounded
UnitStackConfigurationData	MonitoringPlan	0	unbounded

Figure 4
AnalyzerRangeData

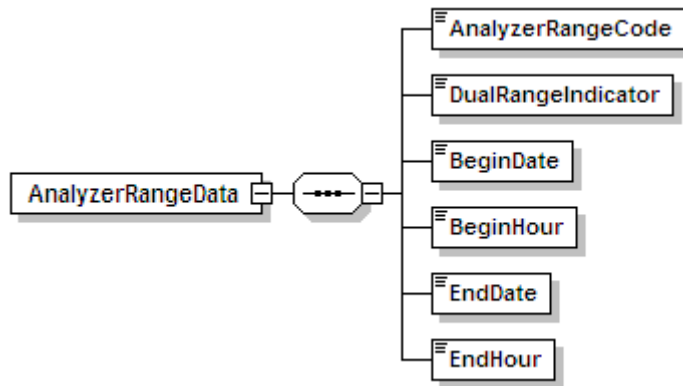

**Figure 5
AnalyzerRangeData XML Elements**

XML Tag	Type	Definition	EDR Reference (RT:Col)
AnalyzerRangeCode	AnalyzerRangeCode Type	Code used to identify the analyzer range.	New
DualRangeIndicator	IndicatorType	Used to indicate whether the component is a dual-range analyzer.	New
BeginDate	OptionalDateType	Date in which information became effective or activity started.	510:100
BeginHour	OptionalHourType	Hour in which information became effective or activity started.	New
EndDate	OptionalDateType	Last date in which information was effective or date in which activity ended.	510:108
EndHour	OptionalHourType	Last hour in which information was effective or hour in which activity ended.	New

**Figure 6
ComponentData**

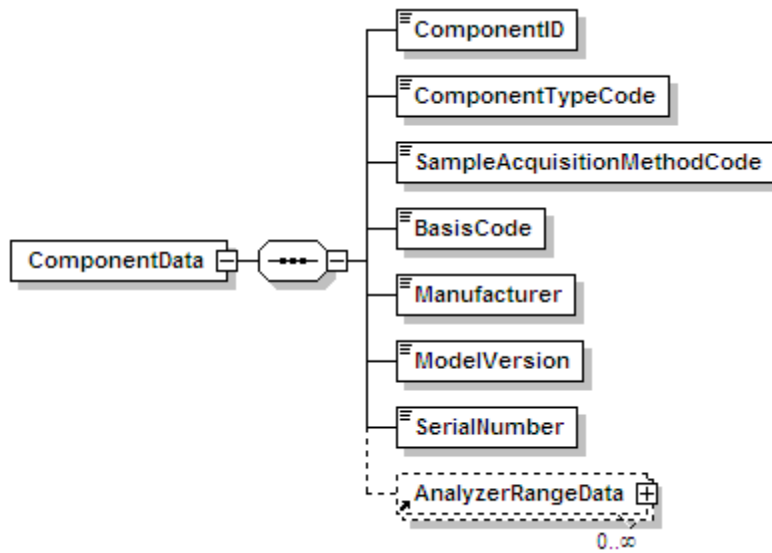

Figure 7
ComponentData XML Elements

XML Tag	Type	Definition	EDR Reference (RT:Col)
ComponentID	RequiredIdentifierType	The three digit code assigned by the source to identify the component.	510:10
ComponentTypeCode	ComponentTypeCode Type	Code used to identify the component type.	N/A
SampleAcquisition MethodCode	AcquisitionMethodCode Type	Code used to identify the sample acquisition method.	510:27
BasisCode	BasisCodeType	Code used to identify the moisture basis.	New
Manufacturer	ManufacturerType	Name of the manufacturer or developer of the component.	510:30
ModelVersion	ModelVersionType	The model of any hardware component or the version number of the software component.	510:55
SerialNumber	SerialNumberType	Serial number of the component.	510:70

Figure 8
MonitoringDefaultData

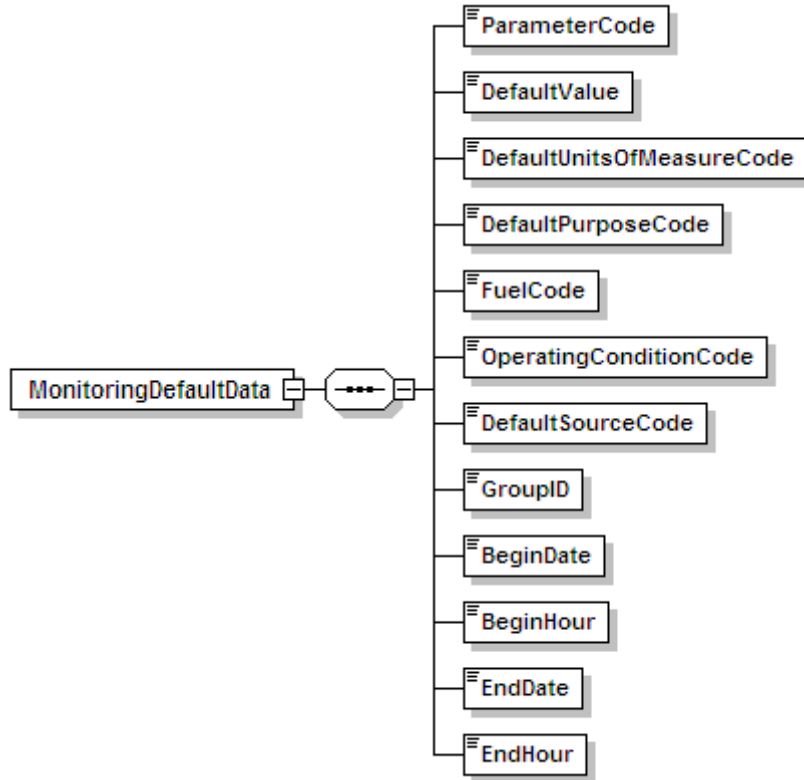

Figure 9
MonitoringDefaultData XML Elements

XML Tag	Type	Definition	EDR Reference (RT:Col)
ParameterCode	DefaultParameterCode Type	Code used to identify the parameter.	531:10
DefaultValue	DefaultValueType	Value of default, maximum, minimum, or constant.	531:14
DefaultUnitsOfMeasureCode	DefaultUnitsOfMeasureCodeType	Code used to identify the hourly parameter units of measure.	N/A
DefaultPurposeCode	DefaultPurposeCode Type	Code used to identify the purpose or intended use of defaults, maximums, and constants.	531:34
FuelCode	FuelCodeType	Code used to identify the type of fuel.	531:37
OperatingConditionCode	OperatingConditionCodeType	Code used to identify the operating condition.	531:40

(cont.)

Figure 9
MonitoringDefaultData XML Elements (cont.)

XML Tag	Type	Definition	EDR Reference (RT:Col)
DefaultSourceCode	DefaultSourceCodeType	Code used to identify the source of the default value.	531:41
GroupID	GroupIDType	For a group of identical units using testing to determine default NO _x rate, this ID identifies the group.	N/A
BeginDate	RequiredDateType	Date on which information became effective or activity started.	531:45
BeginHour	RequiredHourType	Hour in which information became effective.	531:53
EndDate	OptionalDateType	Last date in which information was effective. This date will be null for active records.	531:55
EndHour	OptionalHourType	Last hour in which information was effective. This value will be null for active records.	531:63

Figure 10
MonitoringFormulaData

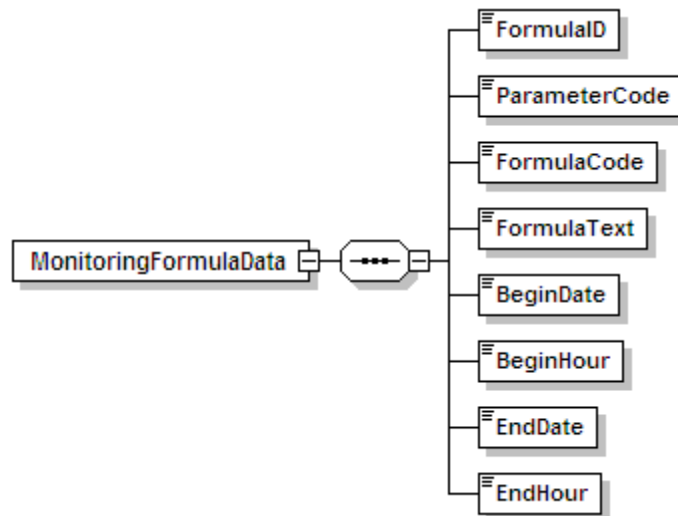

Figure 11
MonitoringFormulaData XML Elements

XML Tag	Type	Definition	EDR Reference (RT:Col)
FormulaID	RequiredFormulaIdentifierType	The three character formula ID assigned by the source.	520:11
ParameterCode	FormulaParameterCodeType	Code used to identify the parameter.	520:14
FormulaCode	EquationCodeType	Code used to identify the equation as defined in Part 75.	520:18
FormulaText	FormulaTextType	The equation used to calculate the parameter.	520:23
BeginDate	OptionalDateType	Date on which information became effective or activity started.	New
BeginHour	OptionalHourType	Hour in which information became effective.	New
EndDate	OptionalDateType	Last date in which information was effective. This date will be null for active records.	New
EndHour	OptionalHourType	Last hour in which information was effective. This value will be null for active records.	New

Figure 12
MonitoringLoadData

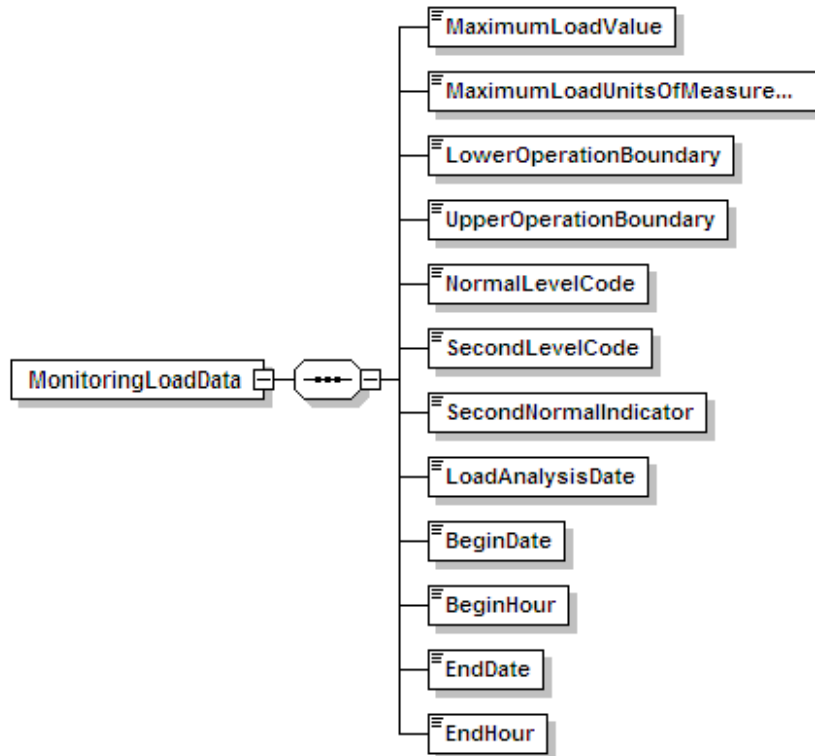

Figure 13
MonitoringLoadData XML Elements

XML Tag	Type	Definition	EDR Reference (RT:Col)
MaximumLoadValue	MaximumLoadValueType	Maximum hourly gross load.	535:12
MaximumLoadUnitsOfMeasureCode	MaximumLoadUnitsOfMeasureCodeType	Code used to identify the units of measure for maximum load value.	535:10
LowerOperationBoundary	LowerOperationBoundaryType	Lower boundary of range of operation.	536:16
UpperOperationBoundary	UpperOperationBoundaryType	Upper boundary of range of operation.	536:10
NormalLevelCode	LevelCodeType	Code used to identify the normal load or operating level.	536:25

(cont.)

Figure 13
MonitoringLoadData XML Elements (cont.)

XML Tag	Type	Definition	EDR Reference (RT:Col)
SecondLevelCode	LevelCodeType	Code used to identify the second most frequently used load or operating level.	536:22
SecondNormalIndicator	IndicatorType	Used to indicate the reporting of an additional normal load or a second operating level.	536:26
LoadAnalysisDate	OptionalDateType	The date in which load analysis was performed. This date only applies to CEM and Appendix D locations.	536:27
BeginDate	RequiredDateType	Date on which information became effective or activity started.	New
BeginHour	RequiredHourType	Hour in which information became effective.	New
EndDate	OptionalDateType	Last date in which information was effective. This date will be null for active records.	536:35
EndHour	OptionalHourType	Last hour in which information was effective. This value will be null for active records.	New

Figure 14
MonitoringLocationData

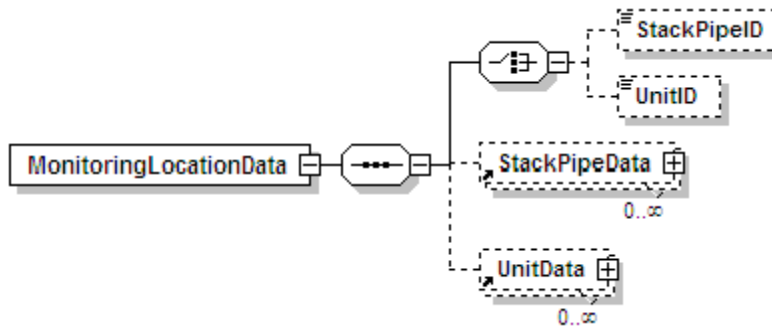

Figure 15
MonitoringLocationData XML Elements

XML Tag	Type	Definition	EDR Reference (RT:Col)
StackPipeID	RequiredStackPipeType	Three to six alphanumeric character code which is assigned by the source to identify a stack or pipe.	N/A
UnitID	RequiredUnitType	One to six alphanumeric character code assigned by the source to identify a unit.	N/A

Figure 16
MonitoringLocationAttribData

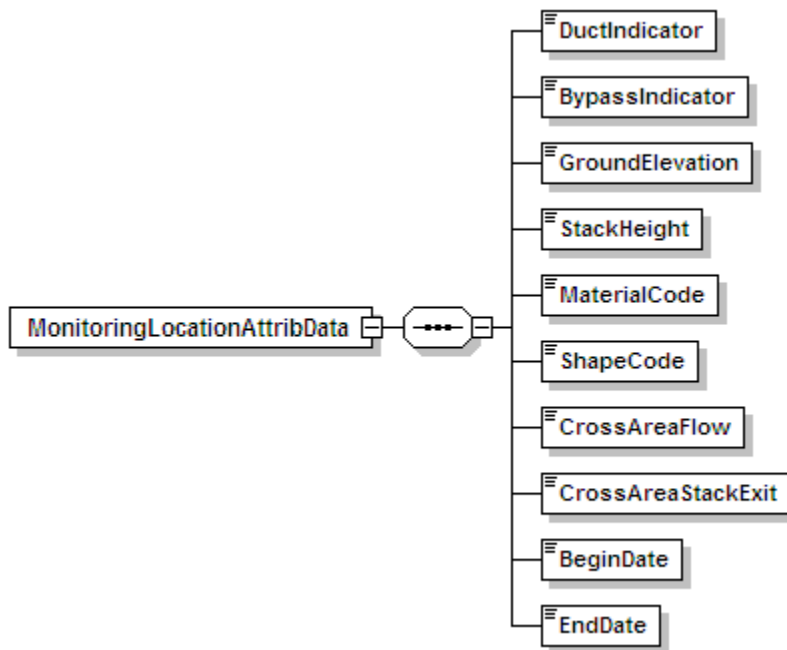
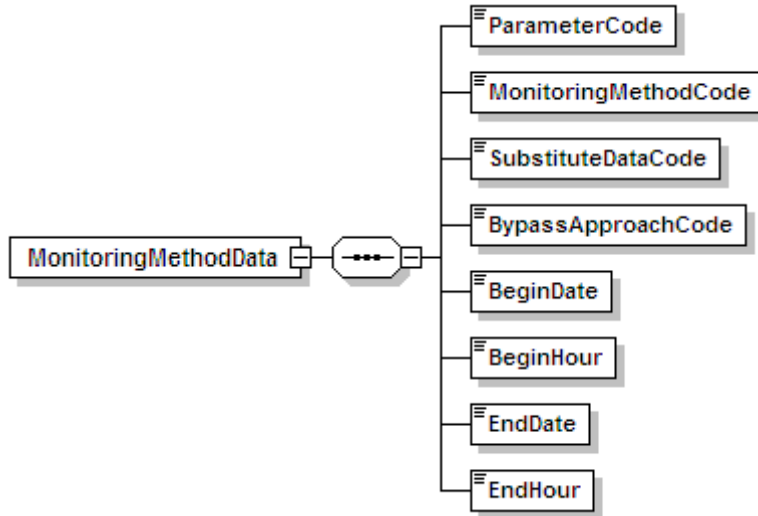

Figure 17
MonitoringLocationAttribData XML Elements

XML Tag	Type	Definition	EDR Reference (RT:Col)
DuctIndicator	IndicatorType	Used to indicate that this location is a duct.	New
BypassIndicator	IndicatorType	Used to indicate that the stack is used for bypass.	503:61
GroundElevation	GroundElevationType	The number of feet above sea level at ground level of the stack or unit.	503:66
StackHeight	StackHeightType	The height in feet of a stack exit above ground level.	503:62
MaterialCode	MaterialCodeType	Code used to identify the material that is used in the monitoring location.	N/A
ShapeCode	ShapeCodeType	Code identifying the shape of a monitor location.	N/A
CrossAreaFlow	CrossAreaFlowType	The reported inside cross-sectional area in square feet of the stack or duct at the flow monitoring location.	503:75
CrossAreaStackExit	CrossAreaStackExitType	The inside cross-sectional area in square feet of the stack at the exit.	503:71
BeginDate	RequiredDateType	Date on which information became effective or activity started.	New
EndDate	OptionalDateType	Last date in which information was effective. This date will be null for active records.	New

**Figure 18
MonitoringMethodData**



**Figure 19
MonitoringMethodData XML Elements**

XML Tag	Type	Definition	EDR Reference (RT:Col)
ParameterCode	MethodParameterCode Type	Code used to identify the parameter.	585:10
MonitoringMethodCode	MethodCodeType	Code used to identify the monitoring methodology.	585:10
SubstituteDataCode	SubstituteDataCodeType	Code used to identify the substitute data approach type.	585:28
BypassApproachCode	BypassApproachCode Type	Code used to identify the value to be used for an unmonitored bypass stack.	N/A
BeginDate	RequiredDateType	Date on which information became effective or activity started.	585:42
BeginHour	RequiredHourType	Hour in which information became effective.	New
EndDate	OptionalDateType	Last date in which information was effective. This date will be null for active records.	585:14
EndHour	OptionalHourType	Last hour in which information was effective. This value will be null for active records.	New

Figure 20
MonitoringPlanCommentData

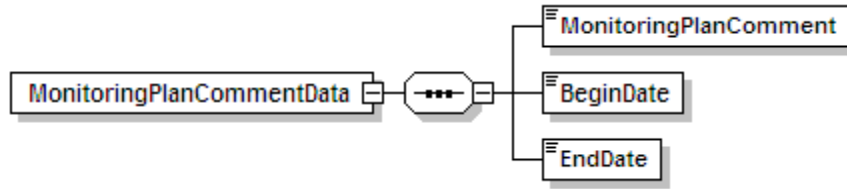

Figure 21
MonitoringPlanCommentData XML Elements

XML Tag	Type	Definition	EDR Reference (RT:Col)
MonitoringPlan Comment	MonitoringPlan CommentType	Comment on a monitoring plan.	910:4
BeginDate	RequiredDateType	Date on which information became effective or activity started.	New
EndDate	OptionalDateType	Last date in which information was effective. This date will be null for active records.	New

Figure 22
MonitoringQualificationData

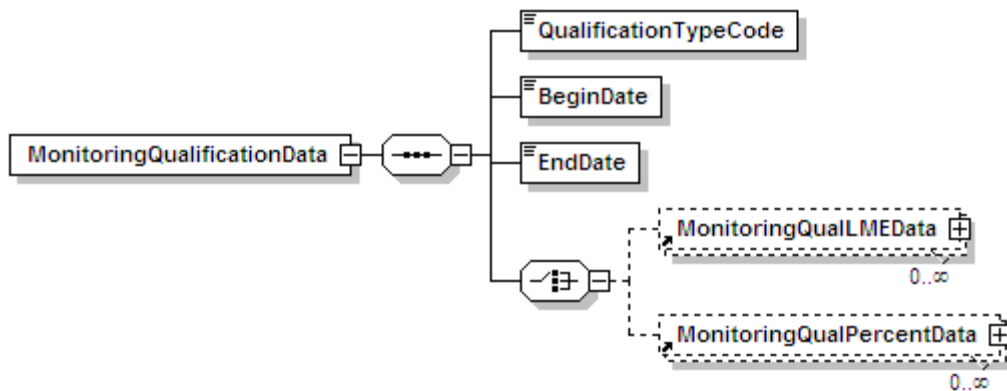

Figure 23
MonitoringQualificationData XML Elements

XML Tag	Type	Definition	EDR Reference (RT:Col)
QualificationTypeCode	QualTypeCodeType	Code used to identify the qualification type.	507:49
BeginDate	RequiredDateType	Date on which information became effective or activity started.	New
EndDate	OptionalDateType	Last date in which information was effective. This date will be null for active records.	N/A

Figure 24
MonitoringQualLMEData

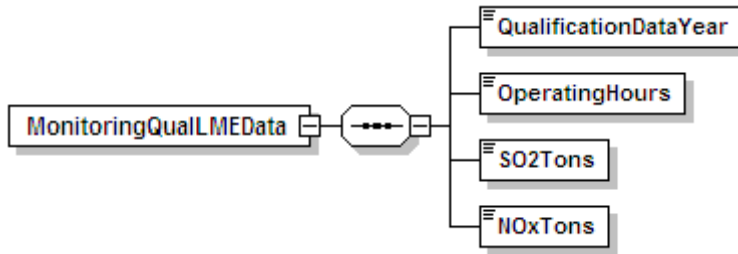

Figure 25
MonitoringQualLMEData XML Elements

XML Tag	Type	Definition	EDR Reference (RT:Col)
QualificationDataYear	RequiredYearType	Year corresponding to the qualification data.	645:16
OperatingHours	OperatingHoursType	Annual number of operating hours used to determine qualification.	645:36
SO2Tons	SO2TonsType	Annual SO ₂ value used to determine qualification.	645:28
NOxTons	NOxTonsType	Annual NO _x emissions to determine qualification n.	645:24

Figure 26
MonitoringQualPercentData

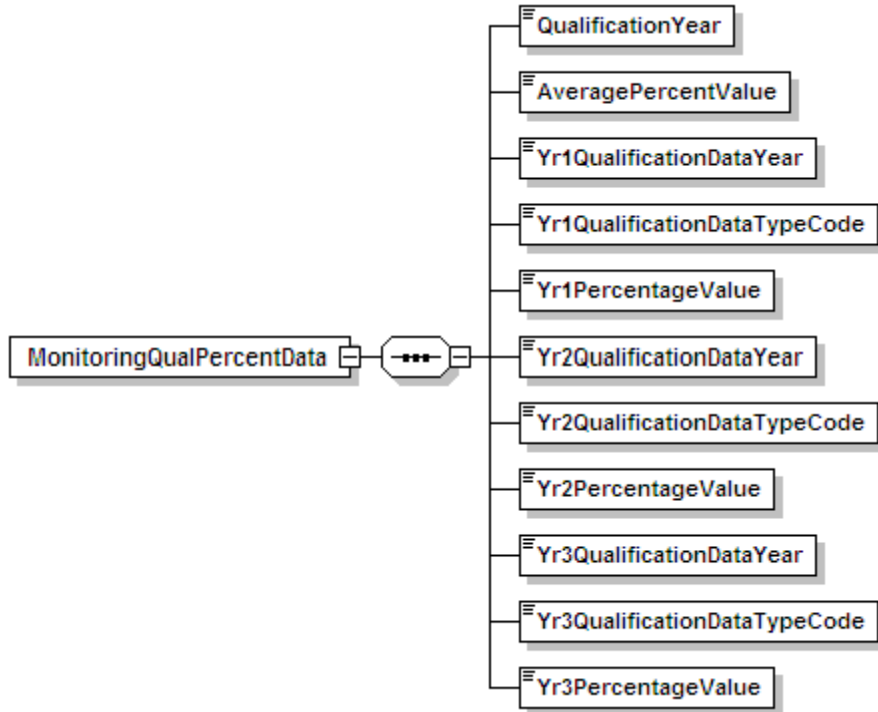

Figure 27
MonitoringQualPercentData XML Elements

XML Tag	Type	Definition	EDR Reference (RT:Col)
QualificationYear	RequiredYearType	Year corresponding to the qualification data.	507:10
AveragePercentValue	AveragePercentValueType	The average percent capacity or heat input usage.	507:44
Yr1QualificationDataYear	OptionalYearType	The first year corresponding to the qualification data.	507:19
Yr1QualificationDataTypeCode	QualDataTypeCodeType	Code used to indicate type of data for year one (actual or projected) used to determine peaking or gas-fired qualification.	507:18
Yr1PercentageValue	PercentageValueType	The percent capacity or heat input usage in the first year.	507:44
Yr2QualificationDataYear	OptionalYearType	The second year corresponding to the qualification data.	507:24

(cont.)

Figure 27
MonitoringQualPercentData XML Elements (cont.)

XML Tag	Type	Definition	EDR Reference (RT:Col)
Yr2QualificationData TypeCode	QualDataTypeCodeType	Code used to indicate type of data for year two (actual or projected) used to determine peaking or gas-fired qualification.	507:28
Yr2PercentageValue	PercentageValueType	The percent capacity or heat input usage in the second year.	507:29
Yr3QualificationData Year	OptionalYearType	The third year corresponding to the qualification data.	507:34
Yr3QualificationData TypeCode	QualDataTypeCodeType	Code used to indicate type of data for year three (actual or projected) used to determine peaking or gas-fired qualification.	507:38
Yr3PercentageValue	PercentageValueType	The percent capacity or heat input usage in the third year.	507:39

Figure 28
MonitoringSpanData

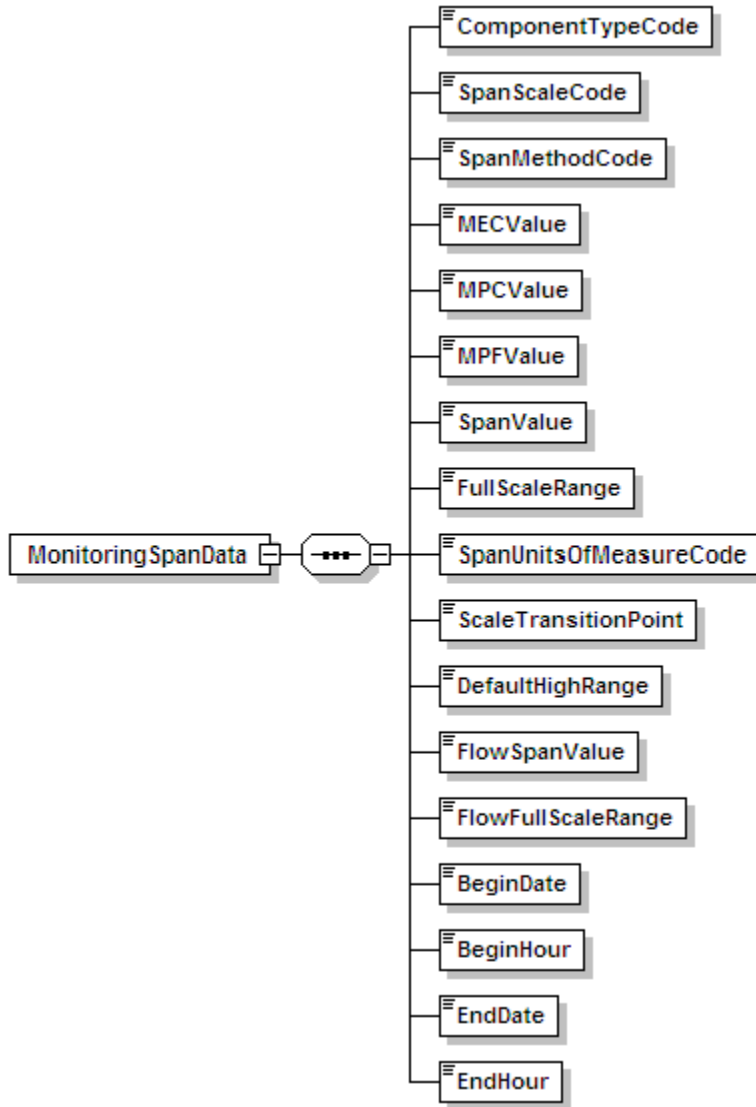

Figure 29
MonitoringSpanData XML Elements

XML Tag	Type	Definition	EDR Reference (RT:Col)
ComponentTypeCode	SpanComponentType CodeType	Code used to indicate the component type.	N/A
SpanScaleCode	SpanScaleCodeType	Code used to identify the span scale.	530:14

(cont.)

Figure 29
MonitoringSpanData XML Elements (cont.)

XML Tag	Type	Definition	EDR Reference (RT:Col)
SpanMethodCode	SpanMethodCodeType	Code used to identify the method used to calculate MPC/MEC/MPF.	530:15
MECValue	MECValueType	Maximum expected concentration (MEC).	530:17
MPCValue	MPCValueType	Maximum potential concentration (MPC).	530:17
MPFValue	MPFValueType	Maximum Potential Flow (MPF).	530:17
SpanValue	SpanValueType	Span value in units of daily calibration.	530:36
FullScaleRange	FullScaleRangeType	Full scale range in units of daily calibration.	530:49
SpanUnitsOfMeasure Code	SpanUnitsOfMeasure CodeType	Code used to identify the calibration units of measure.	N/A
ScaleTransitionPoint	ScaleTransitionPoint Type	Maximum value determined by low-scale of a dual-range analyzer.	New
DefaultHighRange	DefaultHighRangeType	Default High Range value.	530:85
FlowSpanValue	FlowSpanValueType	Flow rate span value in SCFH.	530:90
FlowFullScaleRange	FlowFullScaleRange Type	Flow rate full scale value in SCFH.	530:99
BeginDate	RequiredDateType	Date on which information became effective or activity started.	530:68
BeginHour	RequiredHourType	Hour in which information became effective.	530:74
EndDate	OptionalDateType	Last date in which information was effective. This date will be null for active records.	530:76
EndHour	OptionalHourType	Last hour in which information was effective. This value will be null for active records.	530:82

Figure 30
MonitoringSystemData

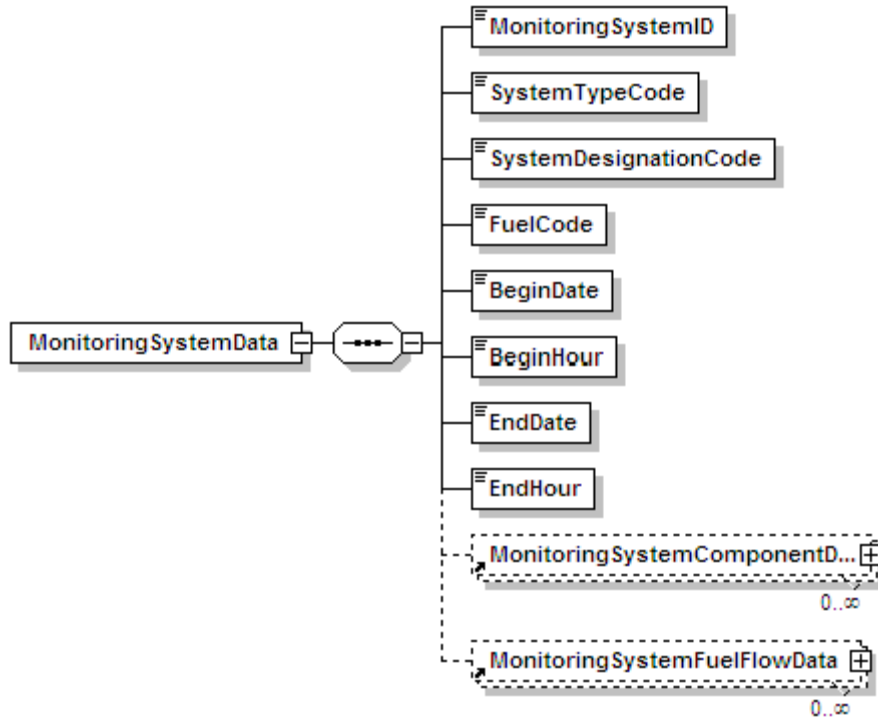

Figure 31
MonitoringSystemData XML Elements

XML Tag	Type	Definition	EDR Reference (RT:Col)
MonitoringSystemID	RequiredIdentifierType	The three digit code used by the source to identify the monitoring system.	510:13
SystemTypeCode	SystemTypeCodeType	Code used to identify the type (parameter) of the system.	New
SystemDesignationCode	SystemDesignationCode Type	Code used to indicate designation of monitoring system as primary, backup, etc.	510:21
FuelCode	SystemFuelCodeType	Code used to identify the type of fuel.	N/A
BeginDate	OptionalDateType	Date on which information became effective or activity started.	510:100

(cont.)

Figure 31
MonitoringSystemData XML Elements (cont.)

XML Tag	Type	Definition	EDR Reference (RT:Col)
BeginHour	OptionalHourType	Hour in which information became effective or activity started.	New
EndDate	OptionalDateType	Last date in which information was effective. This date will be null for active records.	510:108
EndHour	OptionalHourType	Last hour in which information was effective. This value will be null for active records.	New

Figure 32
MonitoringSystemComponentData

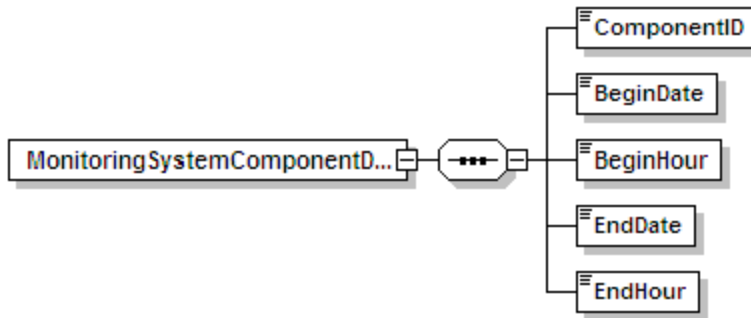

Figure 33
MonitoringSystemComponentData XML Elements

XML Tag	Type	Definition	EDR Reference (RT:Col)
ComponentID	RequiredIdentifierType	The three digit code assigned by the source to identify the component.	N/A
BeginDate	OptionalDateType	Date on which information became effective or activity started.	New
BeginHour	OptionalHourType	Hour in which information became effective.	New

(cont.)

Figure 33
MonitoringSystemComponentData XML Elements (cont.)

XML Tag	Type	Definition	EDR Reference (RT:Col)
EndDate	OptionalDateType	Last date in which information was effective. This date will be null for active records.	New
EndHour	OptionalHourType	Last hour in which information was effective. This value will be null for active records.	New

Figure 34
MonitoringSystemFuelFlowData

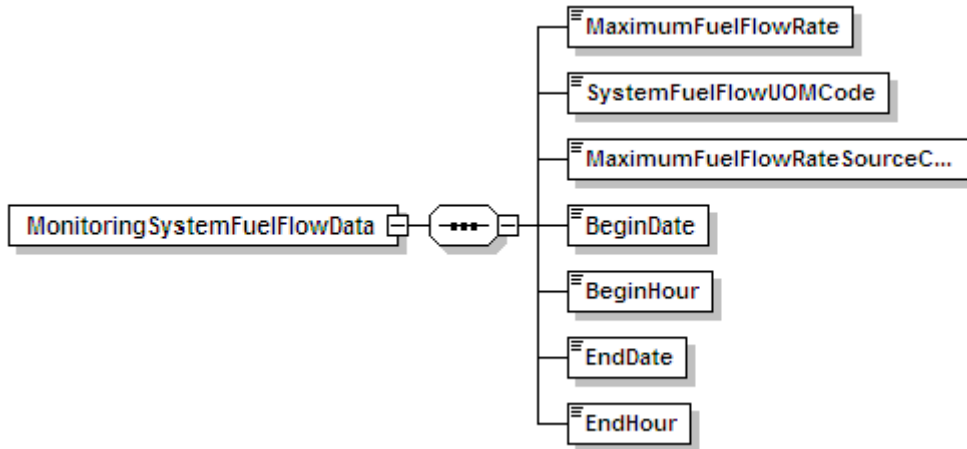

Figure 35
MonitoringSystemFuelFlowData XML Elements

XML Tag	Type	Definition	EDR Reference (RT:Col)
MaximumFuelFlowRate	MaximumFuelFlowRate Type	Maximum fuel flow rate.	540:20
SystemFuelFlowUOM Code	SystemFuelFlowUOM CodeType	Code used to identify the fuel flow units of measure.	N/A
MaximumFuelFlowRate SourceCode	MaxRateSourceCode Type	Code used to identify the source of maximum fuel flow.	540:35

(cont.)

Figure 35
MonitoringSystemFuelFlowData XML Elements (cont.)

XML Tag	Type	Definition	EDR Reference (RT:Col)
BeginDate	OptionalDateType	Date on which information became effective or activity started.	New
BeginHour	OptionalHourType	Hour in which information became effective.	New
EndDate	OptionalDateType	Last date in which information was effective. This date will be null for active records.	New
EndHour	OptionalHourType	Last hour in which information was effective or hour in which activity ended. This value will be null for active records.	New

Figure 36
RectangularDuctWAFData

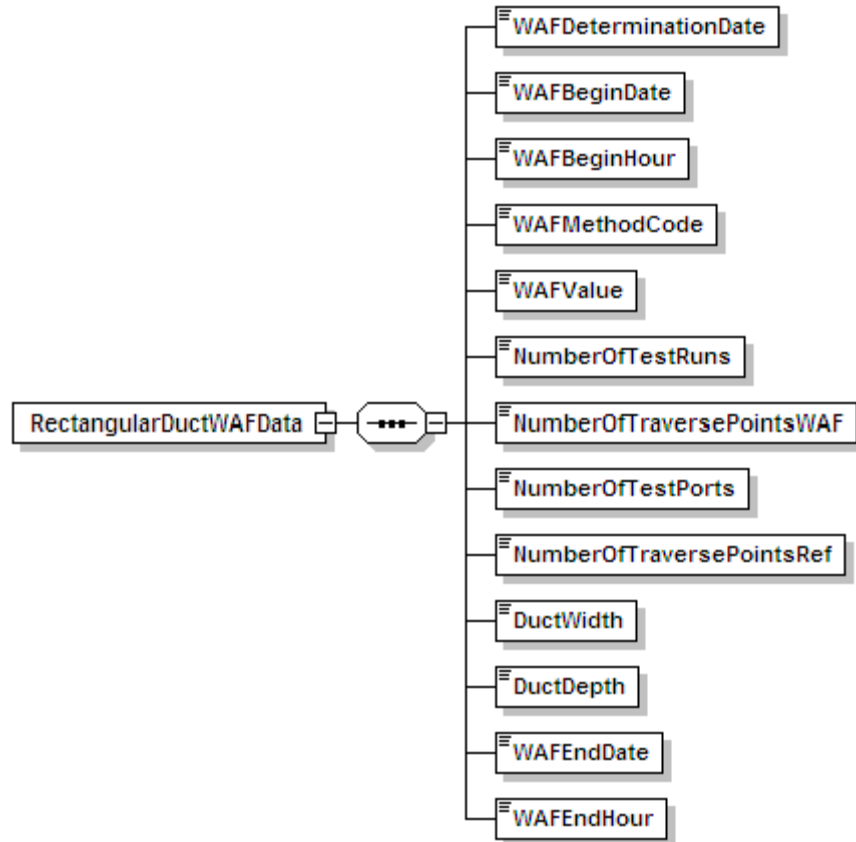
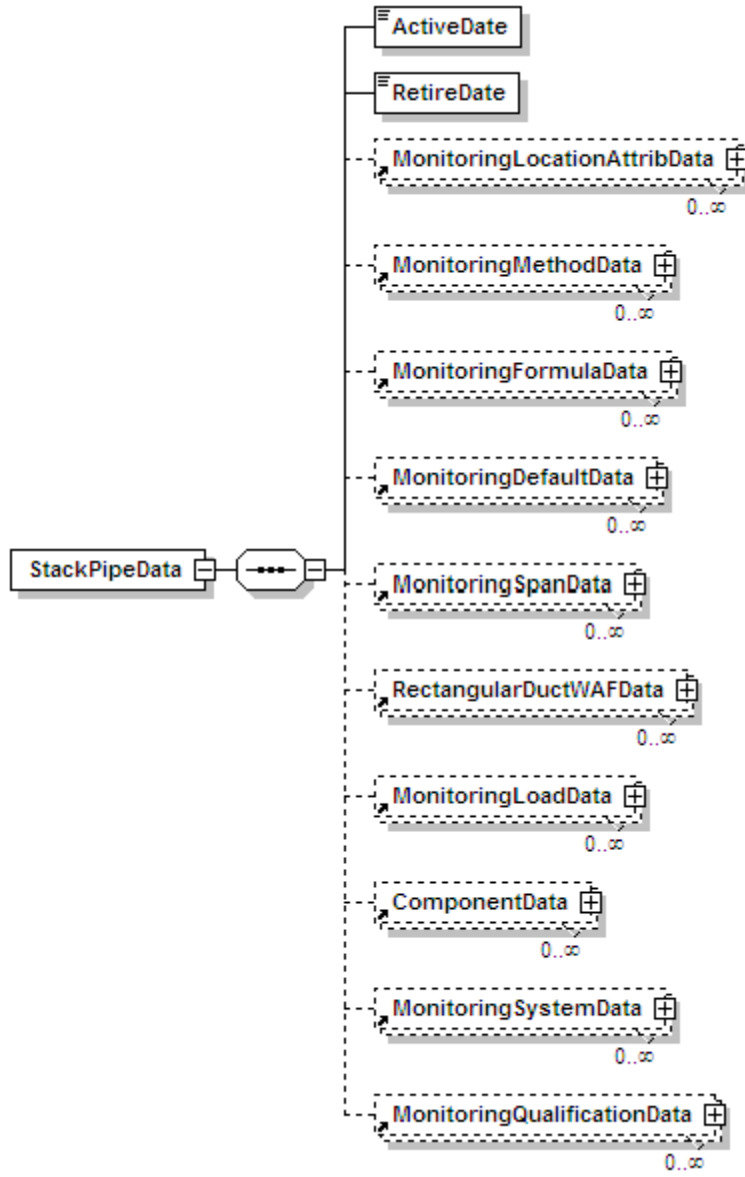

Figure 37
RectangularDuctWAFData XML Elements

XML Tag	Type	Definition	EDR Reference (RT:Col)
WAFDeterminationDate	OptionalDateType	The date the WAF applied was determined.	532:48
WAFBeginDate	RequiredDateType	The date on which the WAF was first applied to the flow rate data.	532:28
WAFBeginHour	RequiredHourType	The hour in which the WAF was first applied to the flow rate data.	532:36
WAFMethodCode	WAFMethodCodeType	Code used to identify the WAF determination method.	532:26
WAFValue	WAFValueType	The WAF applied to the flow rate data, to four decimal places.	532:20
NumberOfTestRuns	NumberOfTestRuns Type	The number of runs in the WAF test (must be one for default WAF and at least three for a measured WAF).	532:56
NumberOfTraverse PointsWAF	NumberOfTraverse PointsWAFType	The number of Method 1 traverse points in the WAF test runs.	532:58
NumberOfTestPorts	NumberOfTestPorts Type	The number of test ports at which measurements were made during the WAF test runs.	532:60
NumberOfTraverse PointsRef	NumberOfTraverse PointsRefType	The number of Method 1 traverse points in the "reference" flow RATA test runs.	532:62
DuctWidth	DuctWidthType	The width of the rectangular duct at the test location to the nearest 0.1 ft (i.e., dimension Lx in Figure 1 of CTM-041).	532:10
DuctDepth	DuctDepthType	The depth of the rectangular duct at the test location to the nearest 0.1 ft (i.e., dimension Ly in Figure 1 of CTM-041).	532:15
WAFEndDate	OptionalDateType	The date on which the WAF was last applied to the flow rate data.	532:38
WAFEndHour	OptionalHourType	The hour in which the WAF was last applied to the flow rate data.	532:46

Figure 38
StackPipeData



**Figure 39
StackPipeData XML Elements**

XML Tag	Type	Definition	EDR Reference (RT:Col)
ActiveDate	RequiredDateType	The date that emissions first went through the stack or the effective date for data reporting.	503:49
RetireDate	OptionalDateType	The actual date that the stack or pipe was last used for emissions measurement or estimation purposes.	503:55

Figure 40
UnitData

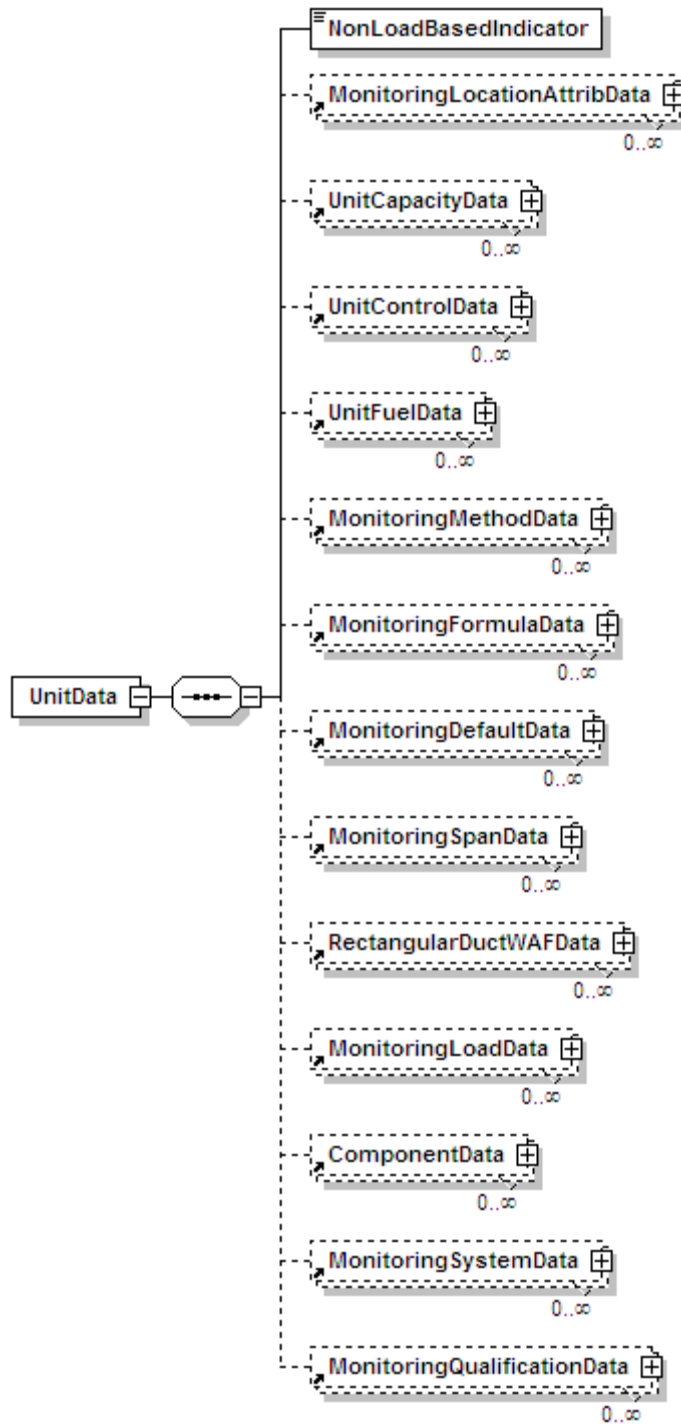

**Figure 41
UnitData XML Elements**

XML Tag	Type	Definition	EDR Reference (RT:Col)
NonLoadBasedIndicator	IndicatorType	Used to indicate whether the unit is non-load based.	504:53

**Figure 42
UnitCapacityData**

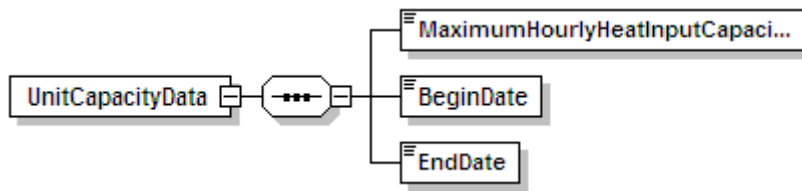

**Figure 43
UnitCapacityData XML Elements**

XML Tag	Type	Definition	EDR Reference (RT:Col)
MaximumHourlyHeat InputCapacity	MaximumHourlyHeat InputCapacityType	The maximum hourly heat input (mmBtu/hr) for the unit.	504:13
BeginDate	RequiredDateType	Date in which information became effective or activity started.	New
EndDate	OptionalDateType	Date on which a relationship or an activity ended.	New

**Figure 44
UnitControlData**

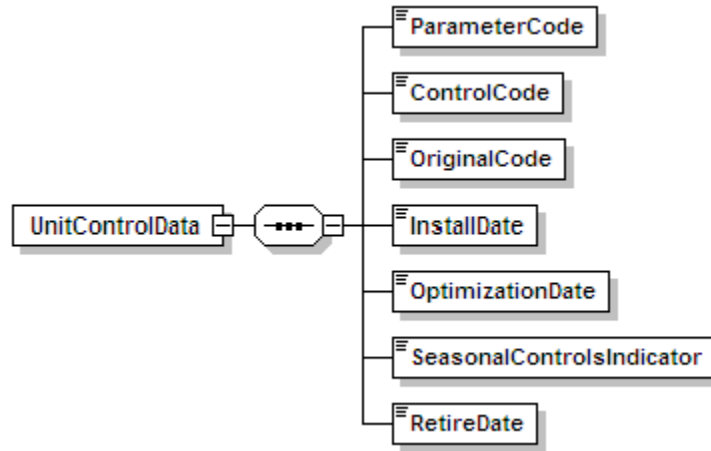

**Figure 45
UnitControlData XML Elements**

XML Tag	Type	Definition	EDR Reference (RT:Col)
ParameterCode	UnitControlParameter CodeType	Code used to identify the continuous emissions parameter for the control.	586:10
ControlCode	ControlCodeType	Code used to identify the control type.	586:14
OriginalCode	IndicatorType	Used to indicate that the control equipment was installed and operated as part of the original unit design.	586:21
InstallDate	OptionalDateType	Date on which information became effective or activity started.	586:22
OptimizationDate	OptionalDateType	The approximate date on which optimization of control equipment was completed and the equipment made fully operational if the control equipment was not part of the original installation.	586:30
SeasonalControls Indicator	IndicatorType	Used to indicate that the NO _x control equipment is used during the ozone season.	586:46
RetireDate	OptionalDateType	Last date in which information was effective. This date will be null for active records.	586:38

**Figure 46
UnitFuelData**

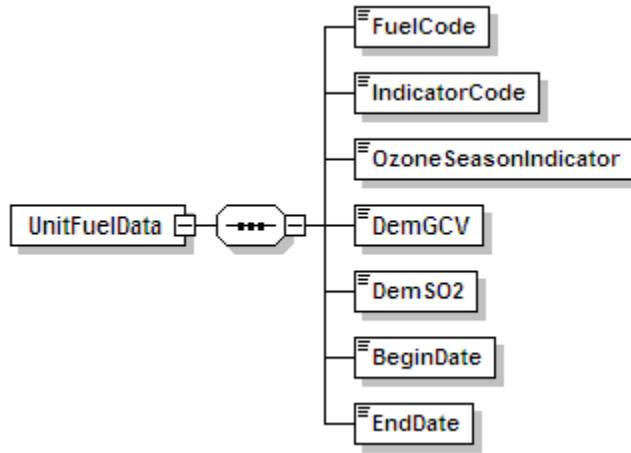

**Figure 47
UnitFuelData XML Elements**

XML Tag	Type	Definition	EDR Reference (RT:Col)
FuelCode	UnitFuelCodeType	Code used to identify the type of fuel which the unit is capable or will be capable of combusting.	587:10
IndicatorCode	IndicatorCodeType	Code used to identify the fuel usage (primary or secondary).	586:20
OzoneSeasonIndicator	IndicatorType	Used to indicate that the fuel is used during ozone season.	587:30
DemGCV	DemMethodCodeType	Demonstration method to qualify for monthly fuel sampling for GCV.	587:31
DemSO2	DemSO2Type	Demonstration method to qualify for daily fuel sampling for percent sulfur.	587:34
BeginDate	RequiredDateType	Date in which information became effective or activity started.	587:13
EndDate	OptionalDateType	Last date in which information was effective. This date will be null for active records.	587:21

Figure 48
UnitStackConfigurationData

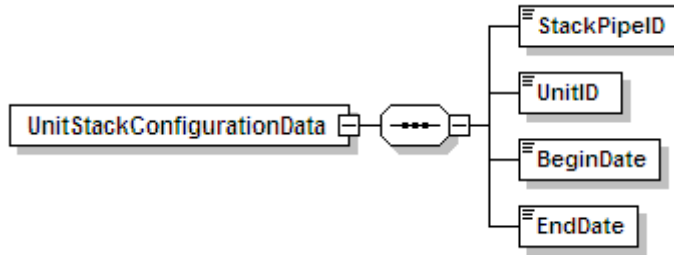

Figure 49
UnitStackConfigurationData XML Elements

XML Tag	Type	Definition	EDR Reference (RT:Col)
StackPipeID	RequiredStackPipeType	Three to six alphanumeric character code which is assigned by the source to identify a stack or pipe.	N/A
UnitID	RequiredUnitType	One to six alphanumeric character code assigned by the source to identify a unit.	N/A
BeginDate	RequiredDateType	Date on which information became effective or activity started.	New
EndDate	OptionalDateType	Last date in which information was effective or date in which activity ended.	New

**Figure 50
Simple Types Used for Validation**

Simple Type Name	Used By	Base	Allow Null Values	Validation Patterns, Restrictions, and Values	Notes
Acquisition MethodCode Type	ComponentData/Sample AcquisitionMethodCode	String	Yes	COR DIL DIN DOU DP EXT IS ISC ISP NOZ O ORF PDP T TUR U VCON VEN VTX WXT	
AnalyzerRange CodeType	AnalyzerRangeData/ AnalyzerRangeCode	String	No	A H L	
AveragePercent Value Type	MonitoringQualPercent Data/AveragePercent Value	Decimal	Yes	Total Digits = 5 Decimal Places = 1	
BasisCodeType	ComponentData/Basis Code	String	Yes	B D W	
BypassApproach CodeType	MonitoringMethodData/ BypassApproachCode	String	Yes	BYMAX BYMAXFS NA	

(cont.)

Figure 50
Simple Types Used for Validation (cont.)

SimpleType Name	Used By	Base	Allow Null Values	Validation Patterns, Restrictions, and Values	Notes
ComponentType CodeType	ComponentData/ ComponentTypeCode	String	No	BGFF BOFF CALR CO2 DAHS DL DP FLC FLOW GCH GFFM H2O NOX O2 OFFM OP PLC PM PRB PRES SO2 TANK TEMP	

(cont.)

**Figure 50
Simple Types Used for Validation (cont.)**

SimpleType Name	Used By	Base	Allow Null Values	Validation Patterns, Restrictions, and Values	Notes
ControlCodeType	UnitControlData/Control Code	String	No	B C CM DA DL DLNB ESP FBL H2O HESP LNB LNBO LNC1 LNC2 LNC3 LNCB MO NH3 O OFA SB SCR SNCR STM WESP WL WLS WS	
CrossAreaFlow Type	MonitoringLocation AttribData/CrossArea Flow	Decimal	Yes	Total Digits = 4 Decimal Places = 0	
CrossAreaStack ExitType	MonitoringLocation AttribData/CrossArea StackExit	Decimal	Yes	Total Digits = 4 Decimal Places = 0	
DefaultHigh RangeType	MonitoringSpanData/ DefaultHighRange	Decimal	Yes	Total Digits = 5 Decimal Places = 0	

(cont.)

Figure 50
Simple Types Used for Validation (cont.)

SimpleType Name	Used By	Base	Allow Null Values	Validation Patterns, Restrictions, and Values	Notes
DefaultParameterCodeType	MonitoringDefaultData/ParameterCode	String	No	CO2N CO2R CO2X FLOX H2O H2ON H2OX MHHI MNGF MNHI MNNX MNOF NOCX NORX NOXR O2N O2X SO2R SO2X SORX	
DefaultPurposeCodeType	MonitoringDefaultData/DefaultPurposeCode	String	Yes	DC DM F23 LM MD PM	
DefaultSourceCodeType	MonitoringDefaultData/DefaultSourceCode	String	Yes	APP CONT DATA DEF MAXD PERM SAMP TEST	
DefaultUnitsOfMeasureCodeType	MonitoringDefaultData/DefaultUnitsOfMeasureCode	String	Yes	BBLHR GALHR HSCF LBHR LBMMBTU M3HR MMBTUHR PCT PPM SCFH TNMMBTU	

(cont.)

Figure 50
Simple Types Used for Validation (cont.)

SimpleType Name	Used By	Base	Allow Null Values	Validation Patterns, Restrictions, and Values	Notes
DefaultValueType	MonitoringDefaultData/DefaultValue	Decimal	No	Total Digits = 15 Decimal Places = 4	
DemMethodCodeType	UnitFuelData/DemGCV	String	Yes	GGC GHS GOC	
DemSO2Type	UnitFuelData/DemSO2	String	Yes	SGC SHS	
DuctDepthType	RectangularDuctWAFData/DuctDepth	Decimal	Yes	Total Digits = 5 Decimal Places = 1	
DuctWidthType	RectangularDuctWAFData/DuctWidth	Decimal	Yes	Total Digits = 5 Decimal Places = 1	
EquationCodeType	MonitoringFormulaData/FormulaCode	String	Yes	19-1 19-14 19-2 19-3 19-3D 19-4 19-5 19-5D 19-6 19-7 19-8 19-9 D-12 D-15 D-15A D-1H D-2 D-3 D-4 D-5 D-6 D-8 E-2 F-1 F-11 F-14A F-14B F-15 F-16 F-17 F-18 F-19	

(cont.)

Figure 50
Simple Types Used for Validation (cont.)

SimpleType Name	Used By	Base	Allow Null Values	Validation Patterns, Restrictions, and Values	Notes
EquationCode Type (cont.)	MonitoringFormulaData/FormulaCode	String	Yes	F-19V F-2 F-20 F-21A F-21B F-21C F-21D F-23 F-24A F-25 F-26A F-26B F-31 F-5 F-6 F-7A F-7B F-8 G-1 G-2 G-3 G-4 G-4A G-5 G-6 G-8 M-1K N-GAS N-OIL NS-1 NS-2 SS-1A SS-1B SS-2A SS-2B SS-2C SS-3A SS-3B T-FL X-FL	
FlowFullScale RangeType	MonitoringSpanData/FlowFullScaleRange	Decimal	Yes	Total Digits = 10 Decimal Places = 0	
FlowSpanValue Type	MonitoringSpanData/FlowSpanValue	Decimal	Yes	Total Digits = 10 Decimal Places = 0	

(cont.)

Figure 50
Simple Types Used for Validation (cont.)

SimpleType Name	Used By	Base	Allow Null Values	Validation Patterns, Restrictions, and Values	Notes
FormulaParameterCodeType	MonitoringFormulaData/ParameterCode	String	No	CO2 CO2C CO2M FC FD FGAS FLOW FOIL FW H2O HI HIT NOX NOXR OILM SO2 SO2R	
FormulaTextType	MonitoringFormulaData/FormulaText	String	No	Minimum Length = 0 Maximum Length = 200 characters	

(cont.)

**Figure 50
Simple Types Used for Validation (cont.)**

SimpleType Name	Used By	Base	Allow Null Values	Validation Patterns, Restrictions, and Values	Notes
FuelCodeType	MonitoringDefaultData/ FuelCode	String	Yes	ANT BFG BT BUT C CDG COG CRF DGG DSL LFG LIG LPG MIX NFS NNG OGS OIL OOL OSF PDG PNG PRG PRP PRS PTC R RFG SRG SUB TDF W WL	
FullScaleRange Type	MonitoringSpanData/ FullScaleRange	Decimal	Yes	Total Digits = 13 Decimal Places = 3	
GroundElevation Type	MonitoringLocation AttribData/Ground Elevation	Decimal	Yes	Total Digits = 5 Decimal Places = 0	
GroupIDType	MonitoringDefaultData/ GroupID	String	Yes	Maximum Length = 10 characters	
IndicatorCode Type	UnitFuelData/Indicator Code	String	Yes	E I P S	

(cont.)

**Figure 50
Simple Types Used for Validation (cont.)**

SimpleType Name	Used By	Base	Allow Null Values	Validation Patterns, Restrictions, and Values	Notes
IndicatorType	AnalyzerRangeData/ DualRangeIndicator MonitoringLoadData/ SecondNormalIndicator MonitoringLocation AttribData/Bypass Indicator MonitoringLocation AttribData/Duct Indicator UnitControlData/ OriginalCode UnitControlData/ SeasonalControls Indicator UnitData/NonLoad BasedIndicator UnitFuelData/Ozone SeasonIndicator	String	Yes	0 1	
LevelCodeType	MonitoringLoadData/ NormalLevelCode MonitoringLoadData/ SecondLevelCode	String	Yes	H L M	
LowerOperation BoundaryType	MonitoringLoadData/ LowerOperation Boundary	Decimal	Yes	Total Digits = 6 Decimal Places = 0	
Manufacturer Type	ComponentData/ Manufacturer	String	No	Maximum Length = 25 characters	
MaterialCode Type	MonitoringLocation AttribData/MaterialCode	String	Yes	BRICK OTHER	
MaximumFuel FlowRateType	MonitoringSystemFuel FlowData/Maximum FuelFlowRate	Decimal	No	Total Digits = 9 Decimal Places = 1	
MaximumHourly HeatInput CapacityType	UnitCapacityData/ MaximumHourlyHeat InputCapacity	Decimal	Yes	Total Digits = 7 Decimal Places = 1	

(cont.)

Figure 50
Simple Types Used for Validation (cont.)

SimpleType Name	Used By	Base	Allow Null Values	Validation Patterns, Restrictions, and Values	Notes
MaximumLoadUnitsOfMeasureCodeType	MonitoringLoadData/MaximumLoadUnitsOfMeasureCode	String	Yes	KLBHR MMBTUHR MW	
MaximumLoadValueType	MonitoringLoadData/MaximumLoadValue	Decimal	Yes	Total Digits = 6 Decimal Places = 0	
MaxRateSourceCodeType	MonitoringSystemFuelFlowData/MaximumFuelFlowRateSourceCode	String	Yes	UMX URV	
MECValueType	MonitoringSpanData/MECValue	Decimal	Yes	Total Digits = 6 Decimal Places = 1	
MethodCodeType	MonitoringMethodData/ MonitoringMethodCode	String	No	AD ADCALC AE AMS CALC CEM CEMF23 CEMNOXR COM EXP F23 FSA LME LTFCALC LTFF MDF MHHI MMS MTB MWD NOXR PEM	

(cont.)

**Figure 50
Simple Types Used for Validation (cont.)**

SimpleType Name	Used By	Base	Allow Null Values	Validation Patterns, Restrictions, and Values	Notes
MethodParameter CodeType	MonitoringMethodData/ParameterCode	String	No	CO2 CO2M H2O HI HIT NOX NOXM NOXR OP PM SO2 SO2M	
ModelVersion Type	ComponentData/Model Version	String	No	Maximum Length = 15 characters	
MonitoringPlan CommentType	MonitoringPlan CommentData/ MonitoringPlan Comment	String	No	Minimum Length = 1 Maximum Length = 4,000 characters	
MPCValueType	MonitoringSpanData/ MPCValue	Decimal	Yes	Total Digits = 6 Decimal Places = 1	
MPFValueType	MonitoringSpanData/ MPFValue	Decimal	Yes	Total Digits = 10 Decimal Places = 0	
NOxTonsType	MonitoringQualLME Data/NOxTons	Decimal	Yes	Total Digits = 4 Decimal Places = 1	
NumberOfTest PortsType	RectangularDuct WAFData/NumberOf TestPorts	Decimal	Yes	Total Digits = 2 Decimal Places = 0	
NumberOfTest RunsType	RectangularDuct WAFData/NumberOf TestRuns	Decimal	Yes	Total Digits = 2 Decimal Places = 0	
NumberOf TraversePoints RefType	RectangularDuct WAFData/NumberOf TraversePointsRef	Decimal	Yes	Total Digits = 2 Decimal Places = 0	
NumberOf TraversePoints WAFType	RectangularDuct WAFData/NumberOf TraversePointsWAF	Decimal	Yes	Total Digits = 2 Decimal Places = 0	

(cont.)

Figure 50
Simple Types Used for Validation (cont.)

SimpleType Name	Used By	Base	Allow Null Values	Validation Patterns, Restrictions, and Values	Notes
OperatingConditionCodeType	MonitoringDefaultData/OperatingConditionCode	String	Yes	A B C P U	
OperatingHoursType	MonitoringQualLMEDData/OperatingHours	Integer	Yes		Must be an integer.

(cont.)

**Figure 50
Simple Types Used for Validation (cont.)**

SimpleType Name	Used By	Base	Allow Null Values	Validation Patterns, Restrictions, and Values	Notes
OptionalDate Type	AnalyzerRangeData/BeginDate AnalyzerRangeData/EndDate MonitoringDefaultData/EndDate MonitoringFormulaData/BeginDate MonitoringFormulaData/EndDate MonitoringLoadData/EndDate MonitoringLoadData/LoadAnalysisDate MonitoringLocationAttribData/EndDate MonitoringMethodData/EndDate MonitoringPlanCommentData/EndDate MonitoringQualificationData/EndDate MonitoringSpanData/EndDate MonitoringSystemComponentData/BeginDate MonitoringSystemComponentData/EndDate MonitoringSystemData/BeginDate	Date	Yes		Must be a date.

(cont.)

Figure 50
Simple Types Used for Validation (cont.)

SimpleType Name	Used By	Base	Allow Null Values	Validation Patterns, Restrictions, and Values	Notes
OptionalDate Type (cont.)	MonitoringSystemData/EndDate MonitoringSystemFuelFlowData/BeginDate MonitoringSystemFuelFlowData/EndDate RectangularDuctWAFData/WAFDeterminationDate RectangularDuctWAFData/WAFEndDate StackPipeData/RetireDate UnitCapacityData/EndDate UnitControlData/InstallDate UnitControlData/OptimizationDate UnitControlData/RetireDate UnitFuelData/EndDate UnitStackConfigurationData/EndDate	Date	Yes		Must be a date.

(cont.)

Figure 50
Simple Types Used for Validation (cont.)

SimpleType Name	Used By	Base	Allow Null Values	Validation Patterns, Restrictions, and Values	Notes
OptionalHour Type	AnalyzerRangeData/BeginHour AnalyzerRangeData/EndHour MonitoringDefaultData/EndHour MonitoringFormulaData/BeginHour MonitoringFormulaData/EndHour MonitoringLoadData/EndHour MonitoringMethodData/EndHour MonitoringSpanData/EndHour MonitoringSystemComponentData/BeginHour MonitoringSystemComponentData/EndHour MonitoringSystemData/BeginHour MonitoringSystemData/EndHour MonitoringSystemFuelFlowData/BeginHour MonitoringSystemFuelFlowData/EndHour RectangularDuctWAFData/WAFEndHour	Decimal	Yes	Minimum Value (inclusive) = 0 Maximum Value (inclusive) = 23	

(cont.)

Figure 50
Simple Types Used for Validation (cont.)

SimpleType Name	Used By	Base	Allow Null Values	Validation Patterns, Restrictions, and Values	Notes
OptionalYear Type	MonitoringQualPercentData/Yr1QualificationDataYear MonitoringQualPercentData/Yr2QualificationDataYear MonitoringQualPercentData/Yr3QualificationDataYear	Integer	Yes	Minimum Value (inclusive) = 1940 Maximum Value (inclusive) = 2050	Four-digit year between 1940 and 2050
ORISCodeType	MonitoringPlan/ORISCode	Integer	No	Minimum Value (inclusive) = 1 Maximum Value (inclusive) = 999999	
PercentageValueType	MonitoringQualPercentData/Yr1PercentageValue MonitoringQualPercentData/Yr2PercentageValue MonitoringQualPercentData/Yr3PercentageValue	Decimal	Yes	Total Digits = 5 Decimal Places = 1	
QualDataTypeCodeType	MonitoringQualPercentData/Yr1QualificationDataTypeCode MonitoringQualPercentData/Yr2QualificationDataTypeCode MonitoringQualPercentData/Yr3QualificationDataTypeCode	String	Yes	A D P	

(cont.)

**Figure 50
Simple Types Used for Validation (cont.)**

SimpleType Name	Used By	Base	Allow Null Values	Validation Patterns, Restrictions, and Values	Notes
QualTypeCode Type	MonitoringQualificationData/QualificationTypeCode	String	No	COMPLEX GF LMEA LMES LOWSULF PK PRATA1 PRATA2 SK	
RequiredDate Type	MonitoringDefaultData/BeginDate MonitoringLoadData/BeginDate MonitoringLocationAttribData/BeginDate MonitoringMethodData/BeginDate MonitoringPlanCommentData/BeginDate MonitoringQualificationData/BeginDate MonitoringSpanData/BeginDate RectangularDuctWAFData/WAFBeginDate StackPipeData/ActiveDate UnitCapacityData/BeginDate UnitFuelData/BeginDate UnitStackConfigurationData/BeginDate	Date	No		Must be a date.

(cont.)

Figure 50
Simple Types Used for Validation (cont.)

SimpleType Name	Used By	Base	Allow Null Values	Validation Patterns, Restrictions, and Values	Notes
RequiredHour Type	MonitoringDefaultData/BeginHour MonitoringLoadData/BeginHour MonitoringMethodData/BeginHour MonitoringSpanData/BeginHour RectangularDuctWAFData/WAFBeginHour	Decimal	No	Minimum Value (inclusive) = 0 Maximum Value (inclusive) = 23	
Required IdentifierType	ComponentData/ComponentID MonitoringFormulaData/FormulaID MonitoringSystemComponentData/ComponentID MonitoringSystemData/MonitoringSystemID	String	No	[A-Z0-9]{1,3}	One to three character alphanumeric string.
Required StackPipeType	MonitoringLocationData/StackPipeID UnitStackConfigurationData/StackPipeID	String	No	(C c M m X x)(S s P p) [A-z0-9]{1,4}	Three to six character string beginning with "CS," "CP," "MS," "MP," or "XS."

(cont.)

Figure 50
Simple Types Used for Validation (cont.)

SimpleType Name	Used By	Base	Allow Null Values	Validation Patterns, Restrictions, and Values	Notes
RequiredUnit Type	MonitoringLocationData/UnitID UnitStackConfigurationData/UnitID	String	No	[A-z0-9 \- *#]{1,6}	One to six character alphanumeric string; also allow asterisk (*), hyphen (-), and pound sign (#).
RequiredYear Type	MonitoringQualLMEDData/QualificationDataYear MonitoringQualPercentData/QualificationYear	Integer	No	(19[0-9][0-9] 20[0-9][0-9])	Four-digit year between 1900 and 2099.
ScaleTransitionPointType	MonitoringSpanData/ScaleTransitionPoint	Decimal	Yes	Total Digits = 6 Decimal Places = 1	
SerialNumber Type	ComponentData/SerialNumber	String	No	Maximum Length = 20 characters	
ShapeCodeType	MonitoringLocationAttribData/ShapeCode	String	Yes	RECT ROUND	
SO2TonsType	MonitoringQualLMEDData/SO2Tons	Decimal	Yes	Total Digits = 4 Decimal Places = 1	
SpanComponentTypeCodeType	MonitoringSpanData/ComponentTypeCode	String	No	CO2 FLOW NOX O2 SO2	
SpanMethodCode Type	MonitoringSpanData/SpanMethodCode	String	Yes	F GS HD ME OL PL TB TR	
SpanScaleCode Type	MonitoringSpanData/SpanScaleCode	String	Yes	H L	

(cont.)

**Figure 50
Simple Types Used for Validation (cont.)**

SimpleType Name	Used By	Base	Allow Null Values	Validation Patterns, Restrictions, and Values	Notes
SpanUnitsOfMeasureCodeType	MonitoringSpanData/ SpanUnitsOfMeasureCode	String	Yes	ACFH ACFM AFPM AMSEC INH2O KACFH KACFM KAFPM KSCFH KSCFM KSFPM MACFH MSCFH PCT PPM SCFH SCFM SFPM SMSEC	
SpanValueType	MonitoringSpanData/ SpanValue	Decimal	Yes	Total Digits = 13 Decimal Places = 3	
StackHeightType	MonitoringLocation AttribData/StackHeight	Decimal	Yes	Total Digits = 4 Decimal Places = 0	
SubstituteDataCodeType	MonitoringMethodData/ SubstituteDataCode	String	Yes	FSP75 FSP75C MHHI NLB NLBOP OZN75 REV75 SPTS	
SystemDesignationCodeType	MonitoringSystemData/ SystemDesignationCode	String	Yes	B CI DB P PB RB RM	

(cont.)

**Figure 50
Simple Types Used for Validation (cont.)**

SimpleType Name	Used By	Base	Allow Null Values	Validation Patterns, Restrictions, and Values	Notes
SystemFuelCode Type	MonitoringSystemData/ FuelCode	String	Yes	BFG BUT CDG COG DGG DSL LFG LPG MIX NFS NNG OGS OIL OOL PDG PNG PRG PRP RFG SRG	
SystemFuelFlow UOMCodeType	MonitoringSystemFuel FlowData/SystemFuel FlowUOMCode	String	No	BBLHR GALHR HSCF LBHR M3HR SCFH	
SystemTypeCode Type	MonitoringSystemData/ SystemTypeCode	String	No	CO2 FLOW GAS H2O H2OM H2OT LTGS LTOL NOX NOXC NOXE NOXP O2 OILM OILV OP PM SO2	

(cont.)

Figure 50
Simple Types Used for Validation (cont.)

SimpleType Name	Used By	Base	Allow Null Values	Validation Patterns, Restrictions, and Values	Notes
UnitControlParameterCodeType	UnitControlData/ParameterCode	String	No	NOX PART SO2	
UnitFuelCodeType	UnitFuelData/FuelCode	String	No	C CRF DSL LPG NNG OGS OIL OOL OSF PNG PRG PRS PTC R TDF W WL	
UpperOperationBoundaryType	MonitoringLoadData/UpperOperationBoundary	Decimal	Yes	Total Digits = 6 Decimal Places = 0	
VersionType	MonitoringPlan/Version	String	Yes	Maximum Length = 10 characters	
WAFMethodCodeType	RectangularDuctWAFData/WAFMethodCode	String	Yes	AT DF FT	
WAFValueType	RectangularDuctWAFData/WAFValue	Decimal	No	Total Digits = 6 Decimal Places = 4	